

X₃

**KEMA
KEUR**
Powered by DEKRA

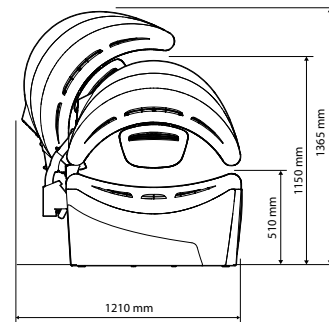
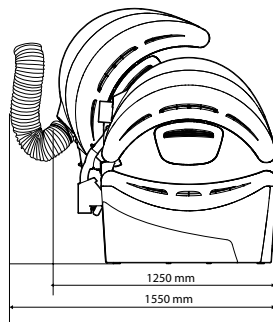
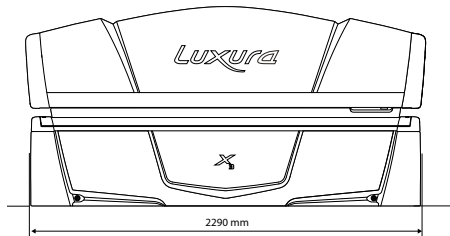

Pearl White

Fuchsia Pink

Lagoon Blue



Deco caps

Connecting shield

Connecting shield plus

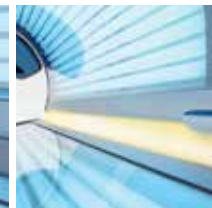

X3

Type	30 SLi	30 SPr	32 SLi	32 SLi Intensive
Tubes	Top: 10 x 120W XL + 6 x 100W Base: 14 x 120W XL	Top: 16 x 120W XL Base: 14 x 120W XL	Top: 18 x 100W Base: 14 x 120W XL	Top: 18 x 160W Base: 14 x 120W XL
Face tanner	1 x 400W	9 x 25W	3 x 400W	3 x 400W
Weight	198 kg	201 kg	217 kg	225 kg
Power / Fuses	3,0kW / 3 x 10A or 1 x 16A	2,8kW / 3 x 10A or 1 x 16A	3,8kW/ 3 x 10A or 1 x 20A	4,7kW / 3 x 10A or 1 x 25A



features

- SPS (not for 30 SPr)
- Face tanners (on/off)
- XL Light
- Eco power bench¹
- 3 steps adjustable body cooler
- "Easy clean" click-profile
- Deco caps
- Digital adjustable timer
- Programmable internal timer
- Connection for external timer
- Hour counter

- Connecting shield
- Connecting shield plus with Ambient FlowLight, Soundbox and My MP3
- Central air exhaust top
- Cover for closure backside
- Face cooler



- Features standard
- Features optional

¹The electronic ballasts - integrated as standard - ensure energy savings of at least 25%.